

LENNART
GROUP
PACKAGING
& PRINTING
MACHINERY
2024
PRODUCT
CATALOG

LENNARTGROUP.BV



LENNART
GROUP

STATE-OF-THE ART MACHINES
A Group of Visionaries Turned a Dream into Reality

Contents

- WHO WE ARE 03
- WHAT WE DO 04
- ECOSAFE BARRIER COATING MACHINE 05-08
- SUSTAINABLE COATINGS 09
- MACHINES FOR PACKAGING 10-13
- KOMPAC AQ/UV COATING MACHINE 14-15

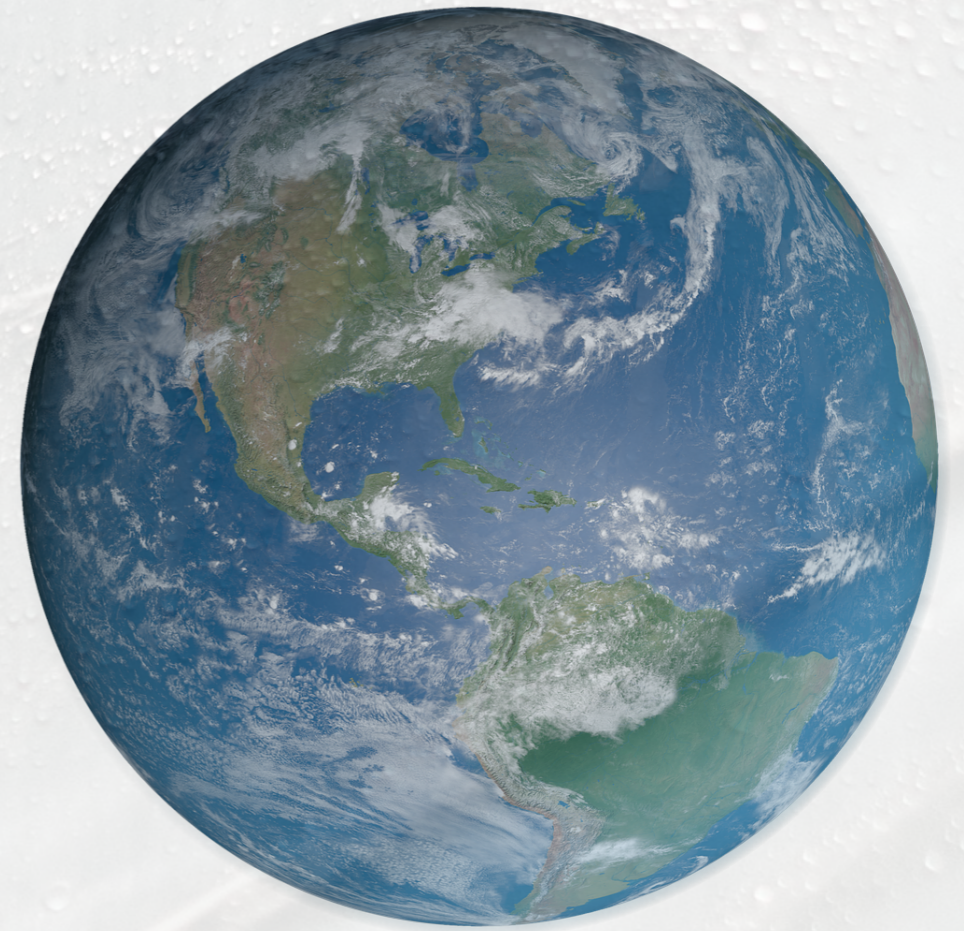

WHO WE ARE

Innovative , Dreamer , Environmental

Our co-founders have dream of creating values for their employees, customers, and environment. That's why , we met in Rotterdam to create a company to make their dreams come true. Each co-founder has different expertise in different fields for many years. We have the marketing, engineering, and managing talents in one basket. Our mentality is to create high technology machinery and products to boost environmental sustainability.

Together with its clients, Lennart Group works towards achieving clear competitive advantages and upgrading company value over the long term. Our customers are our partners. Our mission is to reach zero plastics in all packaging industries. All developments are for sustainable products to create value for our customers and humanity. Together with our partner KOMPAC Technologies ,LLC (USA) . Ecosafe Barrier Coating machine is developed for sustainable packaging .

WHAT WE DO

MULTI CONTINENT

PRODUCTION SITES WITH STRONG PARTNERSHIPS

NETHERLANDS - USA - TURKIYE



PARTERSHIPS

Lennart Group is not only producing machines . We also have partnerships with multi companies for expending globally. Our partners have high expertise in their area.

KOMPAC TECHNOLOGIES ,LLC - USA
CMCC MACHINERY - TURKIYE



E C C O

S U S

P A C

B A R



STATE OF ART BARRIER COATING TECHNOLOGY

Unlocking all potentials

Applying multi coatings in one pass

Wide range of paper 35g/m² - 1200 g/m²

Up to 12 g/m² Wet coating in one module

Patented Hybrid coating system .

Patented Drying system for high performance

Auto coating thickness control (PATENT PENDING)

Coat On-Demand . Speeds up to 120 meters/minute .

Fast change-over (Less than 3 minutes) for different coatings.

Auto Cleaning System (PATENT PENDING)

IOtech4.0 network accessible recipes and database.

Auto Coating Thickness Measurement System

Live Camera integrated

Saves up to 500 different recipes inside system

Integrated multi coating stations (PATENT PENDING)

Less machine space required . Length depends on module

New EcoDry Module for Lower energy consumption



1 g/m²
12 g/m²

Each Module Wet Coating
Thickness



35 gsm
1200 gsm

Minimum Paper Weight
Maximum Paper Weight



140m/min

Eco2web Max Speed



7000
sheet/hour

Eco2sheet Max Speed

6

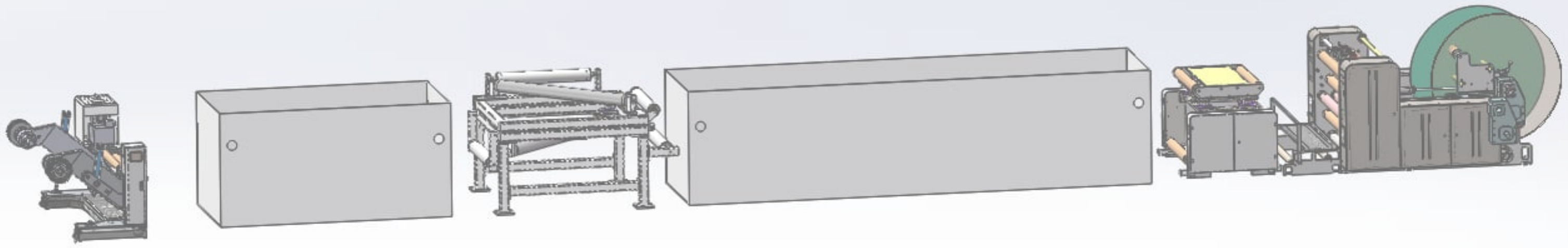

Eco2Web 20"-30"-48"

Widths;

Eco2Web 20" : 50 cm

Eco2Web 30" : 77 cm

Eco2Web 48 : 120 cm

**SUSTAINABLE WATER
BASED COATINGS
VEGAN BASED COATINGS**

**GAME CHANGER
TECHNOLOGY**

MADE IN USA BY

Kompac®

- High Speed up to 120m/min
- Paper weight from 35 gsm to 600 gsm .
- 30 " (770mm) Roll width .
- One Operator Usage
- Coating g/m² : Adjustable up to 6 gram /m² Dry (Each Module)
- Adjustable coating thickness from PLC .
- 3 coating module configurable .
- Jumbo roll Unwinder and Rewinder . (1500mm DIA -55 ")
- Automatic tension control with web guide .
- Double side coating module
- Eco Dry module for low energy consumption
- Slitting Module

**PATENTED MULTI COATING
UP TO 4 + 4 MODULE**

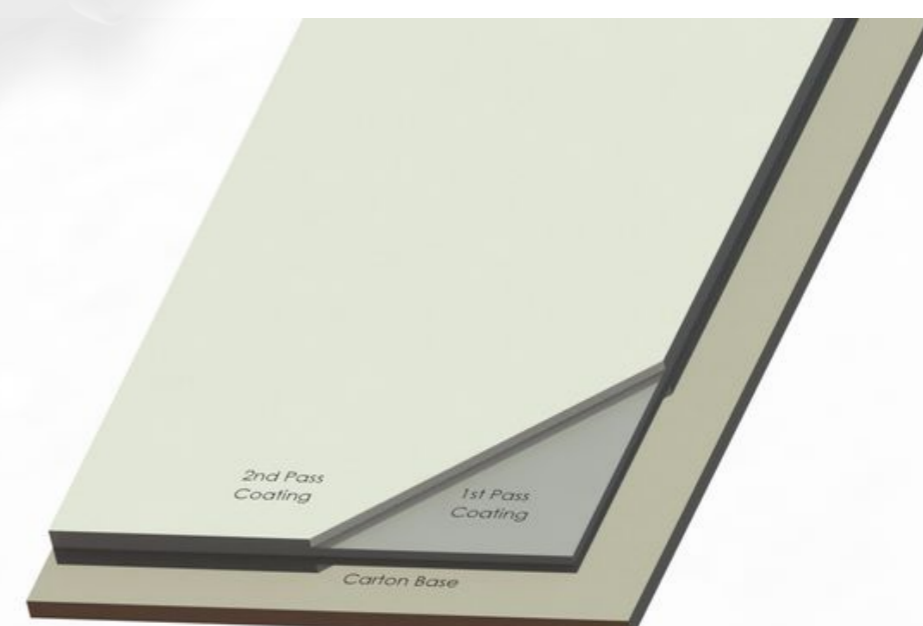

7

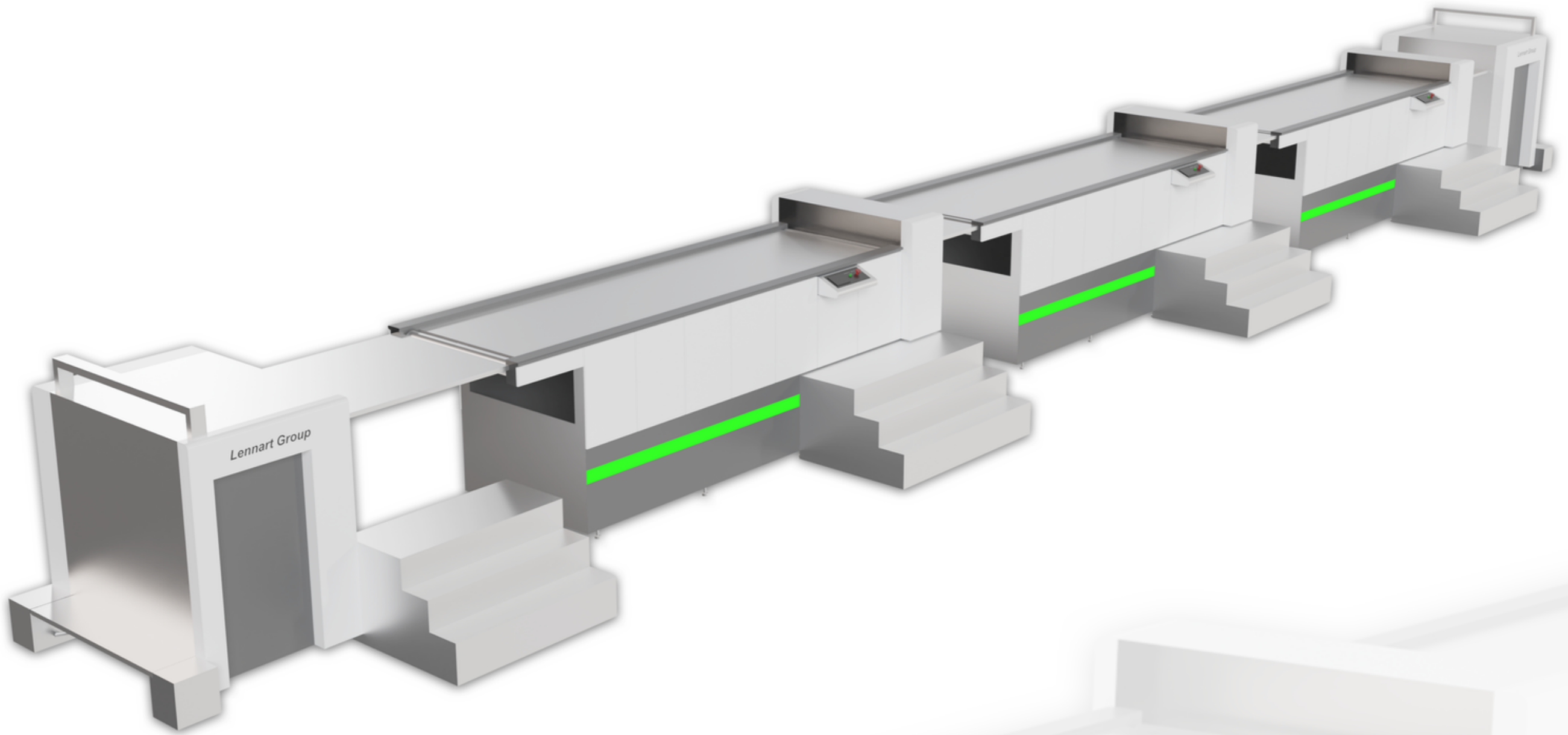

Eco2sheet 20"-30"-48"

Widths ;

Eco2Sheet 20" : 50cm X 105cm

Eco2Sheet 30" : 77cm X 105 cm

**SUSTAINABLE WATER
BASED COATINGS
VEGAN BASED COATINGS**

**COAT ON
DEMAND
TECHNOLOGY**

Kompac®

- Paper weight from 130 gsm to 900 gsm .
- 3 set coating module
- Sheet Turner for double side coating
- Sheet- Jam detections system
- Coating : Adjustable up to 6 gram /m2 DRY (Each Module)
- Up to 7000 sheet/per hour :
- Minimum Sheet Size ;
- High Pile Suction Feeder (1500mm Pallet Height)
- High Pile Pallet stacker (1500mm Pallet Height)
- EcoDry for low energy consumption
- Coat On Demand technology
- One Operator

**IOTECH4.0
INDUSTRY 4.0**



8



Sustainable Water-Based Coatings

Available for Ecosafe Barrier Coating Machine

HEAT SEAL COATING

PERFECT FOR PAPER CUP
APPLICATIONS

FLEXIBLE PACKAGING

WATER BARRIER INTEGRATED

WATER BARRIER

POLYMER OR 50% VEGAN BASE

OIL - GREASE BARRIER

100% VEGAN BASE

100% POLYMER BASE

90 % VEGAN - 10% POLYMER BASE

OVENABLE / OIL BARRIER

UP TO 220 DEGREE - 40 min

PRIMER

POLYMER BASE - CREATING FLAT
SURFACE ON PAPER

OXYGEN BARRIER / MOISTURE BARRIER

CELLULOSE BASE

WATER BASED - PE

State Of the Art PE coating for reducing
extrusion PE applications .

WATER BASED - POLYESTER

Heat Sealable - Biodegradable for
various applications .





LEN 108 BOX BLANKING /STRIPPING MACHINE



**BECKHOFF
AUTOMATION
INTEGRATED**

**500.000 -700.000
BOX/SHIFT**

INDUSTRY 4.0

MADE IN ISTANBUL

- Maximum Sheet Size : 1080 mm (42.5in)X 780 mm (30.7in)
- Minimum Sheet Size : 300mm (11.8 in) X 300 mm (11.8 in)
- Maximum Stripping Size : 550 mm(11.65 in) X 650 mm(25.6 in)
- Minimum Stripping Size : 30 mm(1.18in) X 30 mm(1.18in)
- Speed : 25 Push / min
- Maximum Pile Height : 110 mm (4.3in)
- Double Head for 2 angle jobs
- Beckhoff Automation with Industry 4.0 (Online service & Job Report)
- 19" Beckhoff Touch Screen with Servo System
- Rexroth Hydraulics (Pistons-Valve-Block)
- Schmersal Security Sensor
- Festo Pneumatics
- Solid Robost Mechanical design
- Machine Power : 5 KW - 110V-380V
- Machine Weight : 3200 KG
- Machine Size : 3750mm X 1800 mm X 1900 mm

 **SCHMERSAL**
THE DNA OF SAFETY

rexroth
A Bosch Company

EtherCAT 

FESTO

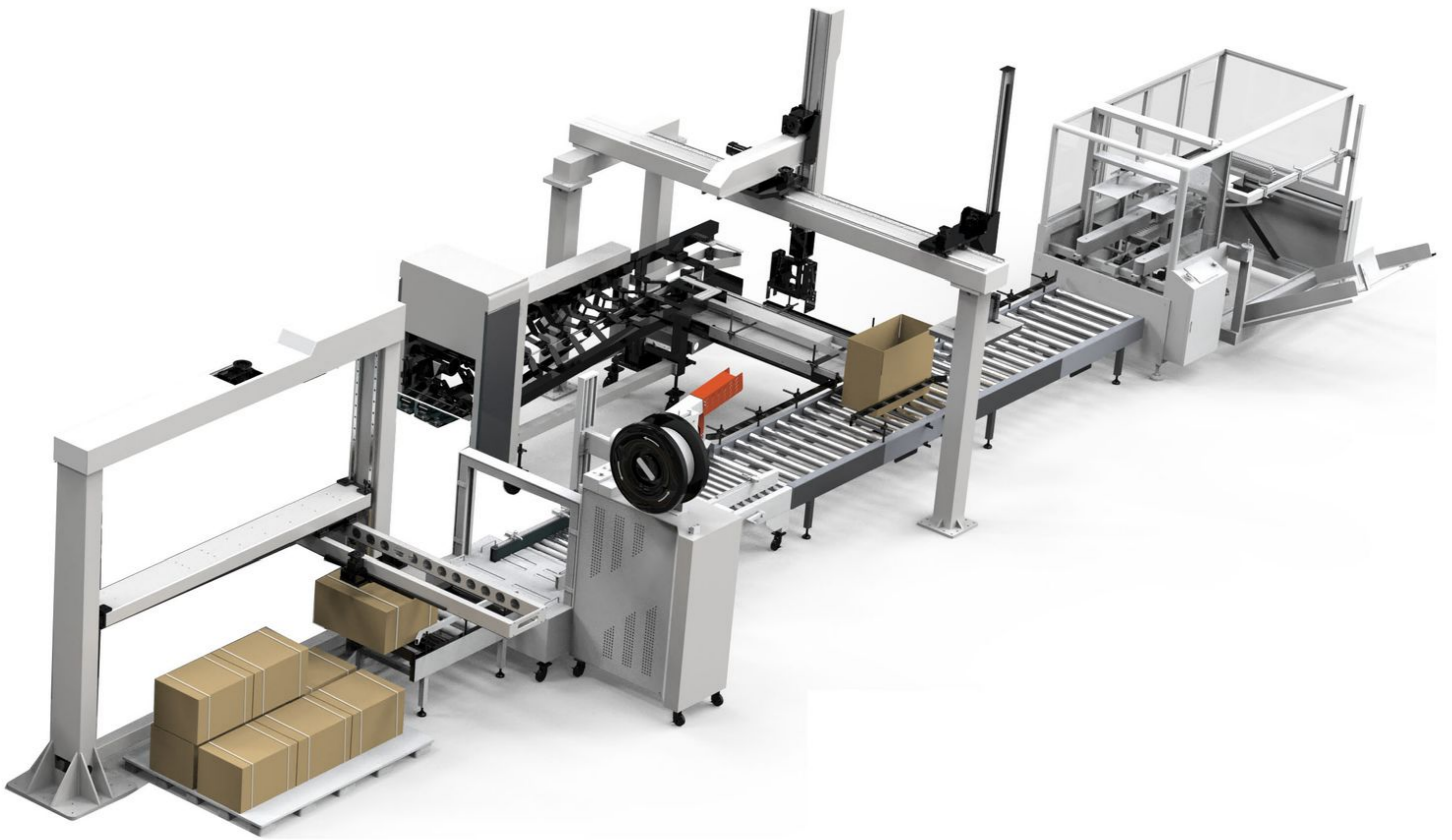

**EASY
INTEGRATION TO
ALL FOLDING
BOX GLUERS**

**AUTOMATION
INDUSTRY 4.0**

HARMONIA FOLDING BOX COLLECTING AND PACKAGING LINE

- Box width 120mm-350mm
- Box inner width 80mm-320mm
- Box height 70mm-350mm
- Clamping size 350mm-500mm
-
- Clamping and Loading speed
- Clamping 300pcs boxes, 68000 - 72000pcs/h
- Clamping 400pcs boxes, 90000 - 96000pcs/h
- Clamping 500pcs boxes, 110000 - 120000pcs/h
-
- Max. loading speed: 4cartons/min
- Pallet size 1200×1200mm
- Palletizing height 1550mm
- Palletizing speed 4cartons/min
- Max. weight of carton ≤30kgs

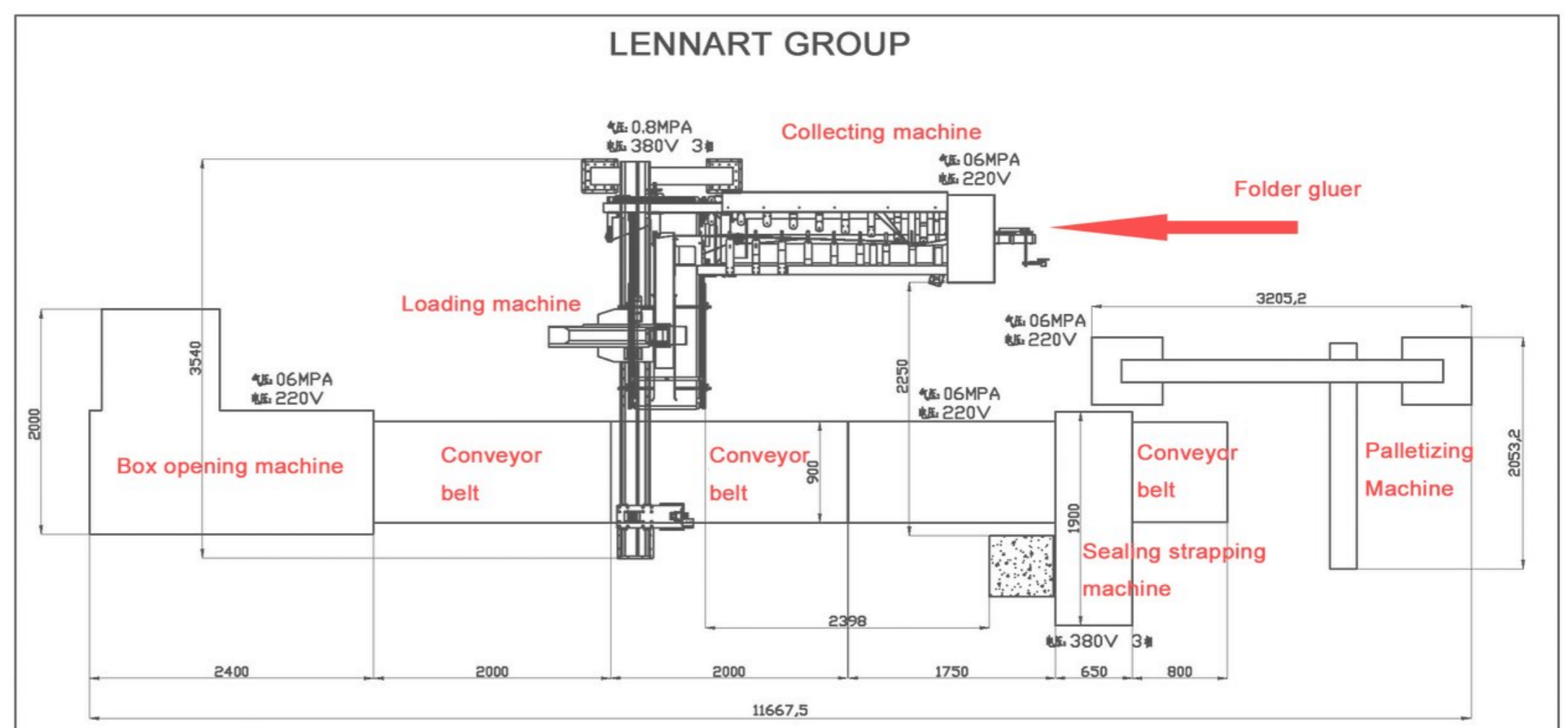

Auto Folding Box collecting and Packaging Line

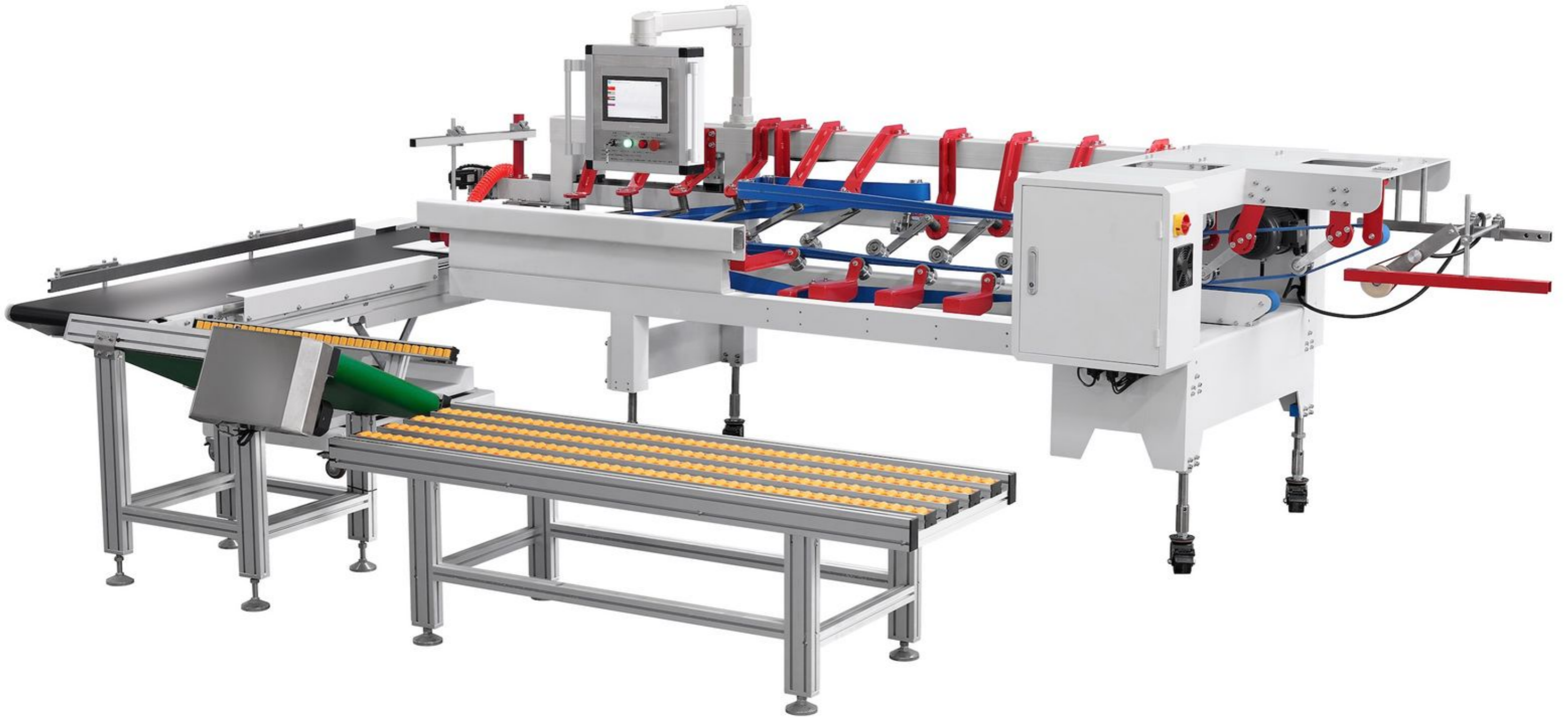

**EASY
INTEGRATION TO
ALL FOLDING
BOX GLUERS**

**AUTOMATION
INDUSTRY 4.0**

HARMONIA 600XL FOLDING BOX COLLECTING MACHINE AUTO SIZE ADJUSTING

- Model : Harmonia 600 XL - Industry 4.0 Integrated .
- Application: Cardboard, corrugated board E, N & F Craft Paper , E FLUTE ,
Straight line Double wall/ Crash lock bottom ,
4&6 corner/ Board case
- Max width: 50mm(1.96in)-550mm(21.65in)
- Max height: 80mm (3.14in)-540mm(21.25in)
- Speed : (20.000- 40.000 box / hour) One Operator
- (60.000- 80.000 box / hour) Two Operator
- Total power: 2 Kw
- Servo Motor : 2 Set
- Dimension: 3500mm(11.4ft)*2400mm(7,87ft)*1620mm(5.31ft)
- Weight: 1100kgs

ECO650 AUTO BOX PRE-FEEDER



MIN. SHEET SIZE :	120MM(W)(4,72") X 120MM(L)(4,72")
MAX. SHEET SIZE :	650MM(W)(25,6") X 400MM(L)(15,7")
LOADING CONVEYOR :	1,240 MM(42,3")
DIMENSION :	2,850 MM(L)(113") X 1,280MM (W)(50,4") X 1,560MM (H)(61.4")

**EASY
INTEGRATION TO
ALL FOLDING
BOX GLUERS**

**AUTOMATIC FEEDING
MADE IN KOREA**



M A T

D I G

G L O

S F T

PHOENIX AQ/UV COATING MACHINE

Kompac

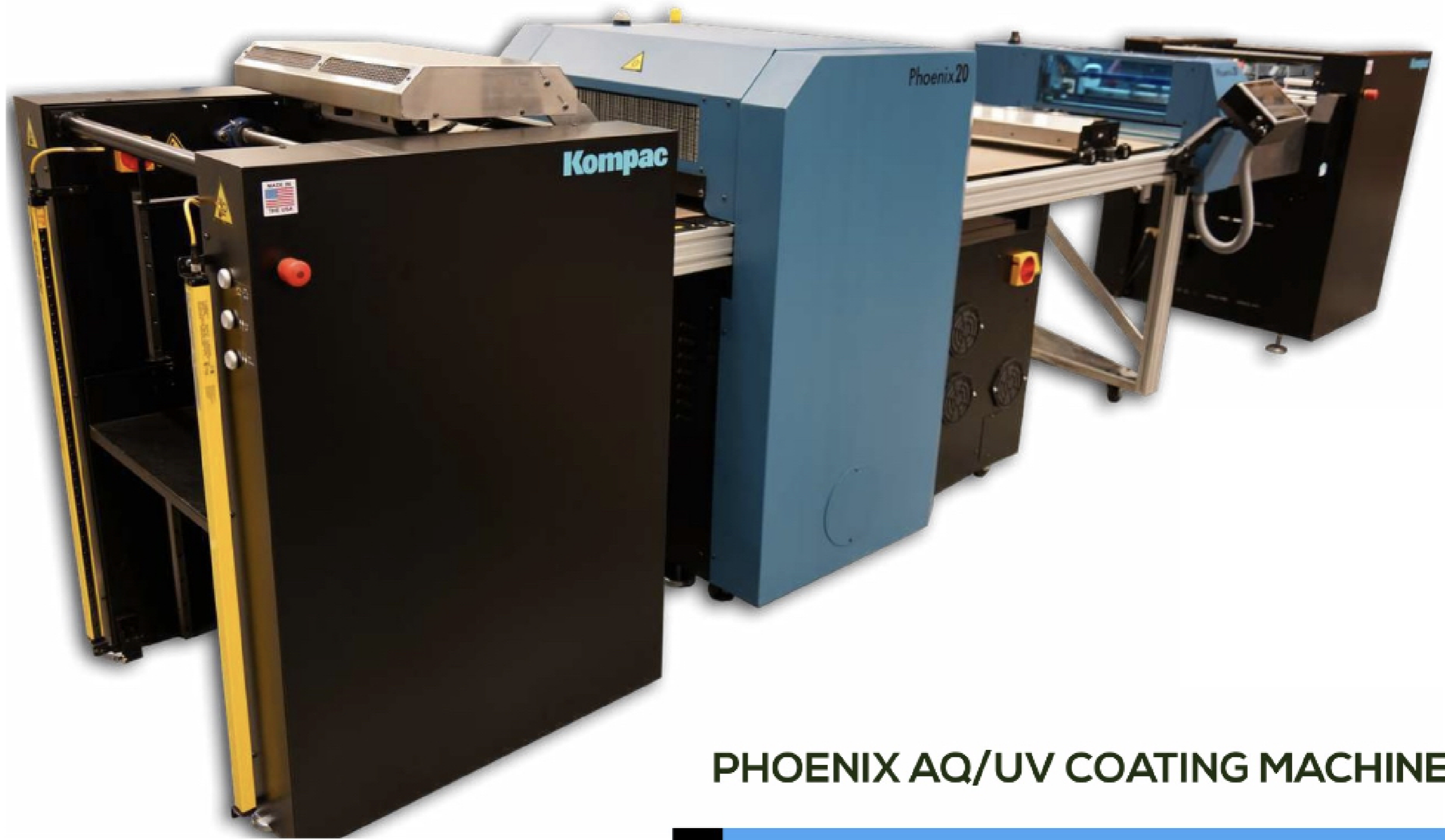

PHOENIX AQ/UV COATING MACHINE

Phoenix 20"-30"

Widths :

Phoenix 20" : 50cm X 102cm

Phoenix 30" : 77cm X 102 cm

- Paper weight from 130 gsm to 540 gsm
- Sheet Turner for double side coating
- Sheet- Jam detections system
- UV and Water Based Coatings
- Anilox Roller upgrade for Matte and Soft Touch
- Online working with HP & FUJI and etc .
- Up to 4000 sheet/per hour (30" X 40") (77 cm X 105 cm)
- Minimum Sheet Size ; (10" X 10") (25 cm X 25 cm)
- Automatic Suction feeder .
- Automatic Pallet stacker
- Solid State UV Drier
- I/R Driers integrated

MATTE
GLOSS
SOFT TOUCH
PRIME (DIGITAL)
A/Q & UV

Kompac





**LENNART
GROUP**

EMEA - APAC

Lennart Group B.V.

Address: Burgemeester Prinsensingel 84 ,4701 HP, Roosendaal
, The Netherlands
Tel : +31 618887010

www.lennartgroup.nl

E-mail: info@lennartgroup.nl

Lennart Group, LLC

3 Germay Dr. UNIT 4 #1430
Wilmington , Delaware , 19804

Tel / MOB : +1(908) 952 3286

www.lennartgroup.us

E-Mail : cem@lennartgroup.us

Lennart Group ,LLC is operating under Kompac Technologies ,LLC

Kompac[®]

LENNART GROUP
NETHERLANDS- USA

LENNARTGROUP.BV